

Status update on SPECTRAP detectors - GEANT4 code for ESR mirror systems

V.M. Hannen, D. Anielski, R. Jöhren, C. Weinheimer
Institut für Kernphysik, Westfälische Wilhelms-Universität Münster

- Detector systems
- Developments regarding NIR detection
- Single photon sources
- Optical GEANT4 simulations
- Outlook

UV region

$^{209}\text{Bi}^{82+}$ (244 nm)

PerkinElmer
C1993P

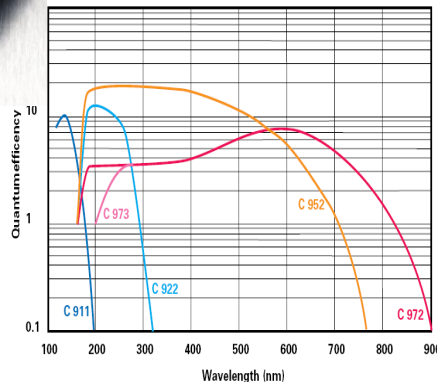

NIR region

$^{207}\text{Pb}^{81+}$ (1020 nm)

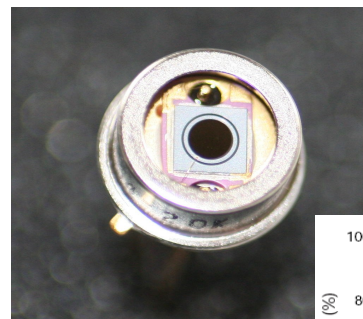

Hamamatsu
S8664-20K

alternatively:
RMD S0223

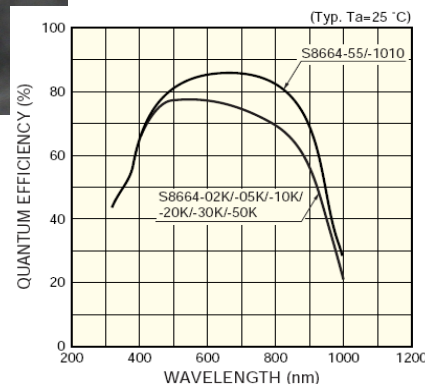

NIR region

$^{209}\text{Bi}^{80+}$ (1555 nm)



Hamamatsu
H10330-75

Intevac IPD

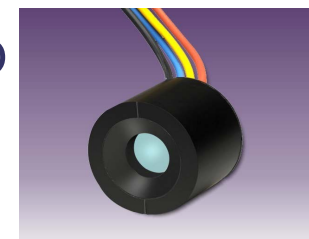

Model	C1993P	S8664-20K	H10330-75	Intevac IPD
Type	Channel PMT	APD	NIR PMT	Hybrid PMT
Active area	Ø = 15 mm	Ø = 2 mm	Ø = 1.6 mm	Ø = 1 mm
Wavelength	244 nm	1020 nm	1555 nm	1555 nm
QA	18%	20%	2%	8%
Dark counts	20 Hz	50 kHz ?	200 kHz	1 MHz
Comment	under test at ESR	under test at Uni Münster		applied for funding

To detect a resonance with $n_\sigma = 3$ significance we need to detect

$$S = s \cdot t \cdot \epsilon \geq n_\sigma \cdot \sqrt{d \cdot t}$$

s = signal rate

t = measurement time

ϵ = efficiency

d = dark count rate

photons.

The required time to do so is at least: $t = \left(\frac{n_\sigma}{s} \right)^2 \frac{d}{\epsilon^2}$

so with numbers given for the Intevac IPD we get for the 1555 nm line:

$$t = \left(\frac{3}{3400} \right)^2 \frac{1 \cdot 10^6}{(0.08 \cdot 0.65)^2} = 288 \text{ s}$$

for the required time per measurement point ... is this feasible ?

→ To shorten measurement times we look for an improvement in either the dark count rate or the QE or both.

For the BMBF application we got in contact with Intevac again and got the following statement:

A counting efficiency of 15% at room temperature is reasonable, but we would expect degradation at lower temperature. We are not sure how much. Some very limited data suggests that retaining about 50% of room temperature QE at -50°C could be possible. We presently have a contract to study this question and to build an optimum cathode for low temperature (-60°C) operation. The contract is expected to run until the end of 2009 so we expect to have data later next year.

...

We would like the opportunity of working with you on this project. ... Mr. Derek Sykora, a principal IPD engineer, would be happy to discuss these issues further with you.

Using the effect of Parametric-Down-Conversion in a non-linear crystal one can build a correlated single photon source

→ possibility to calibrate photon counting detector without knowledge of the absolute flux

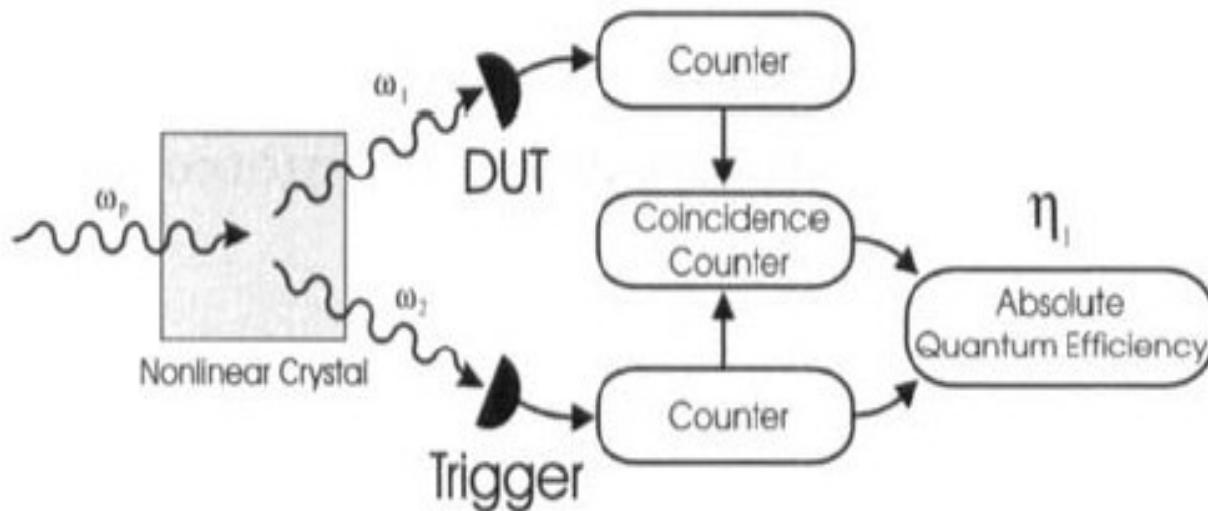

$$N_1 = \eta_1 N$$

$$N_2 = \eta_2 N$$

$$N_{\text{Coinc}} = \eta_1 \eta_2 N$$

$$\eta_1 = \frac{N_{\text{Coinc}}}{N_2}$$

- Realization of suitable source for 1020 nm and 1555 nm in collaboration with the group of Prof. T. Walther at TU Darmstadt (depends on funding from BMBF)
- A poor man's version of such a source for calibration of single photon counting at 1020 nm wavelength could be set up at Münster with support from Prof. C. Denz (Applied Physics Institute)

- Optical simulations for SPECTRAP detectors performed by Daniel Hampf using the KOJAC package, but: difficult to implement new optical elements (mirrors), not quite usable for simulations of ESR detection systems
- GEANT4 includes all necessary optical photon processes (refraction, reflection, absorption, Rayleigh scattering, etc.), originally mainly for simulation of Cerenkov and scintillation detectors
 - suitable for our purpose, easy to implement new optical elements, easy to implement realistic photon sources (ESR and SPECTRAP) and it's free software ...
- Currently used for simulation of ESR optics (new parabolic detection system, existing mirror section), will be extended to SPECTRAP optics
- Results of current simulations in Denis's talk ...

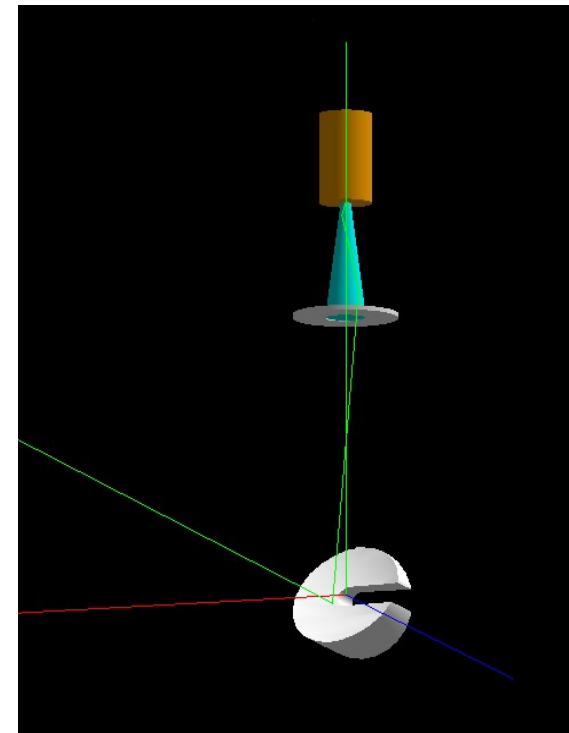
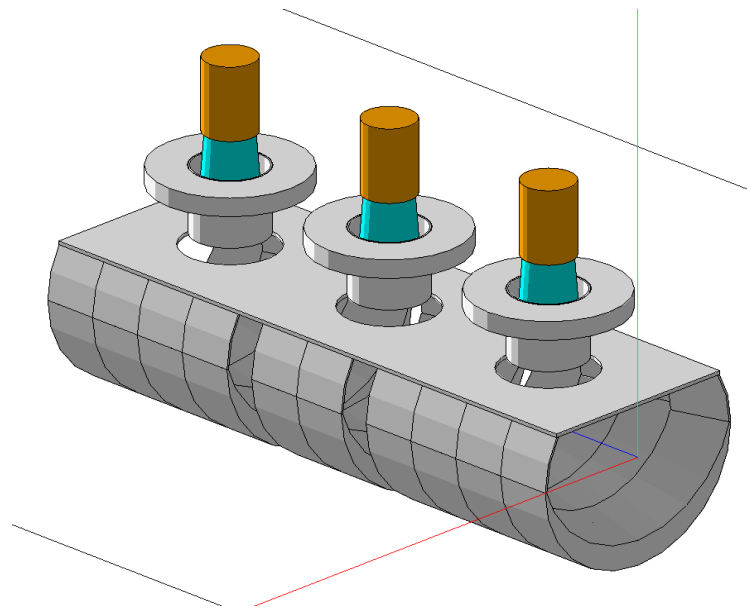

- Continue work on APDs (Hamamatsu / RMD) at low temperatures and on low noise preamp electronics (see R. Jöhren's talk)
- Need to check on realistic numbers for the measurement procedure
- Supposed the funding gets granted, we hope for a good collaboration with Intevac (or Hamamatsu) on NIR detector development
- Also depending on the funding we hope to set up suitable single photon sources to determine PDE for NIR detectors
- Adapt optical GEANT4 simulations developed for ESR to SPECTRAP geometry