

# Radioactive Ion Beam Development — *Chemistry in ISOL targets and ion sources*

4<sup>th</sup> VISTARS Workshop on Nuclear Astrophysics  
March 4<sup>th</sup> -10<sup>th</sup>, 2007 Russbach, Austria

### ISOL beams

### Selective Adsorption

- offline – Thermochromatography
- online – Tests at ISOLDE
- current work and plans

### Holifield Radioactive Ion Beam Facility

### Beam development at Oak Ridge

# ISOL beams

## ISOL-principle

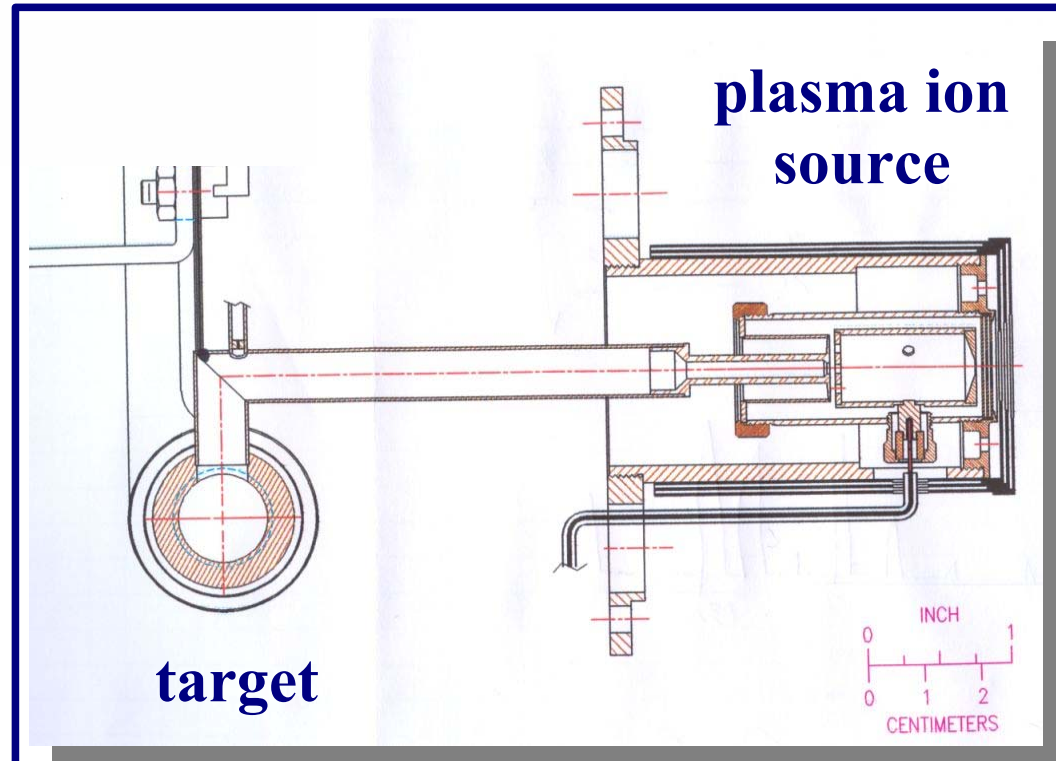
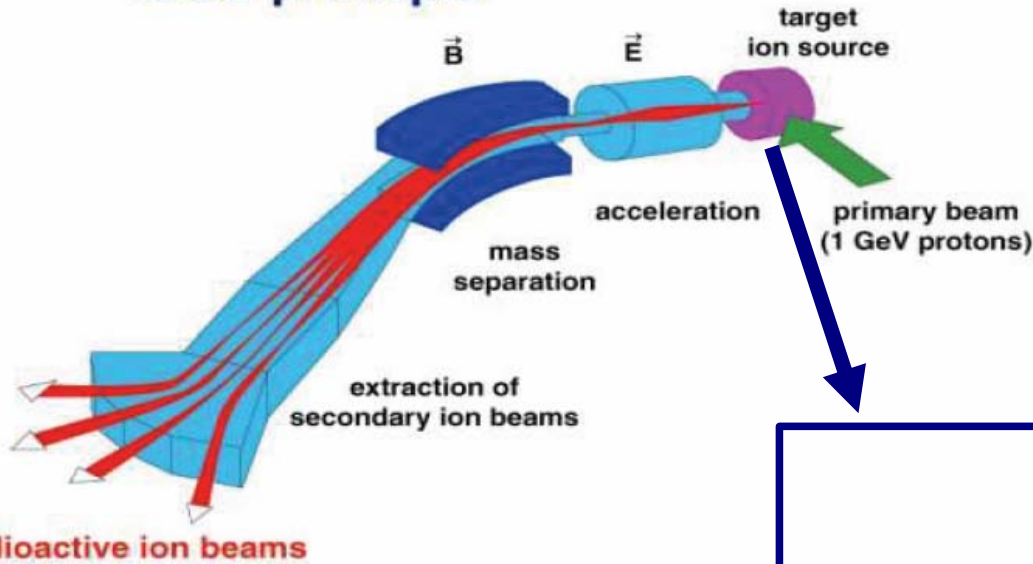

Element dependence:

- Diffusion within target
- Desorption from target
- Effusion (sticking on surface between target and ion source)
- Ionization

## Problem:

Current resolution of mass separators cannot remove isobaric contaminations

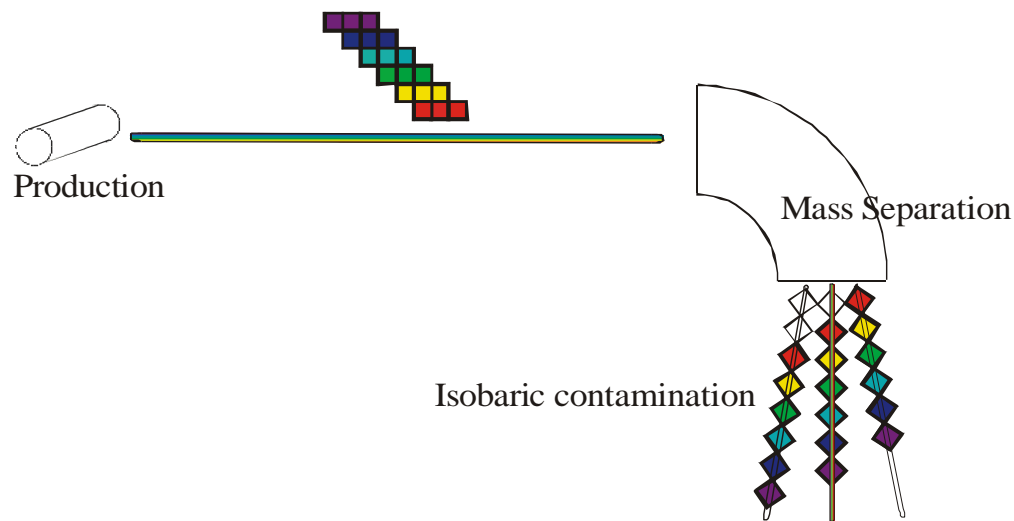

## Solution:

Element-selective methods of transport and ionization

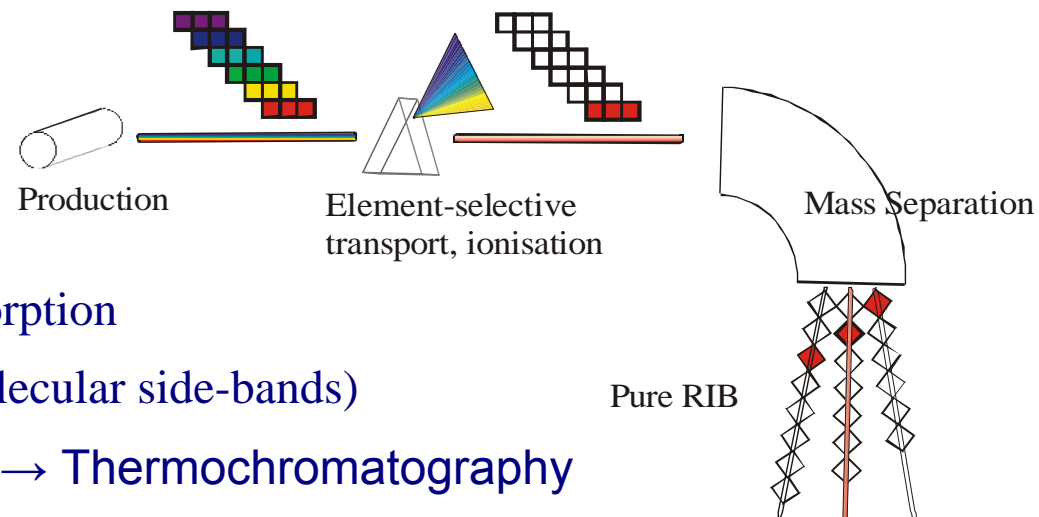

- Target material, for fast diffusion and desorption
- Chemical state of transported element (molecular side-bands)
- **Transfer line material and temperature** → Thermochromatography
- Ionization method (surface, laser)

# Selective Adsorption: Thermochromatography

## Off-line Experiments at CERN-ISOLDE and TRIGA Mainz

### Basic idea of thermochromatography:

Elements or compounds show different retention on given surface due to specific residence time:

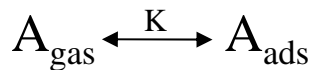

K is temperature dependent

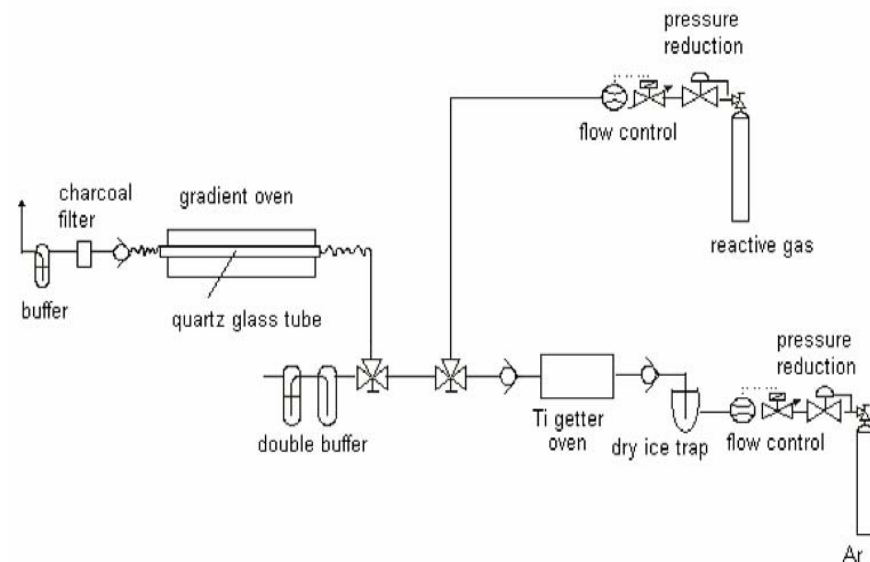
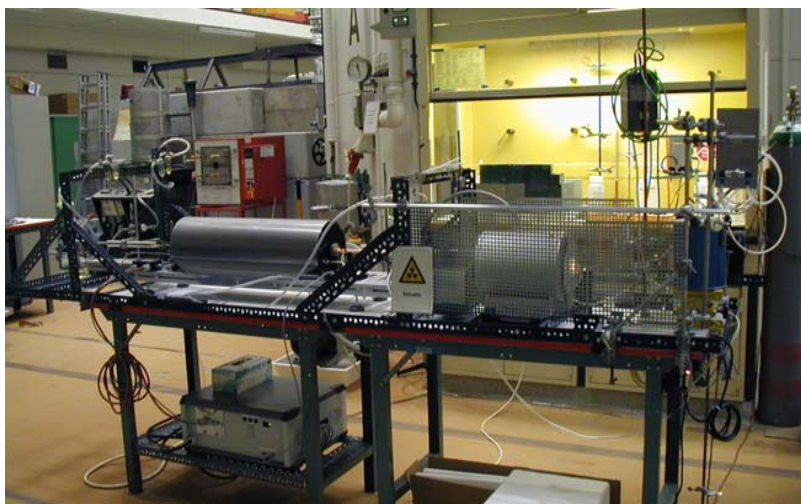
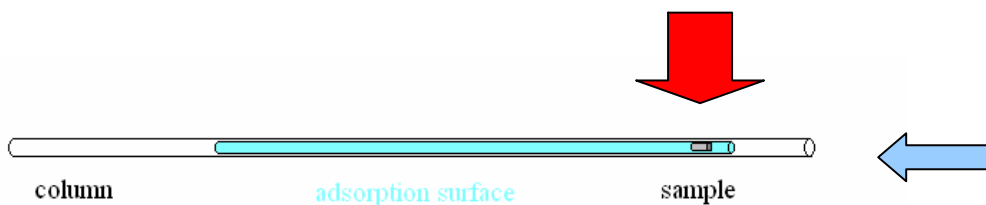

# Thermochromatography - Results

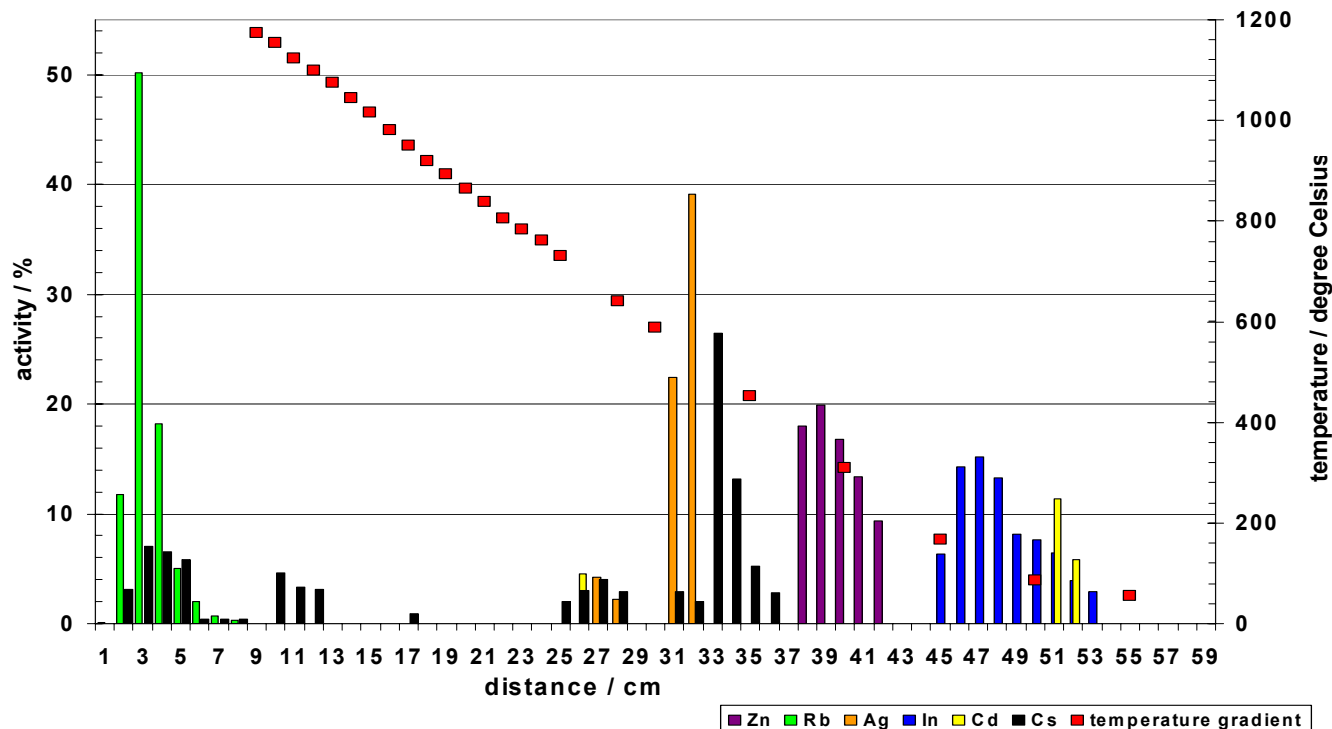

Thermochromatogram of quartz surface,  
max. temperature 1200° Celsius,  
Ar gas flow 100scc/min

- Zn, Ag, In and Cd form defined adsorption peaks at specific temperatures
- Alkali metals show **immediate adsorption** on quartz glass surface
  - $-\Delta H_{\text{ads}} > 285 \text{ kJ / mol}$  from model calculations for Rb
  - **chemisorption, irreversible**

# On-line Experiments at CERN-ISOLDE:

A quartz transfer line for separation of Rb/Zn and Cs/In/Cd

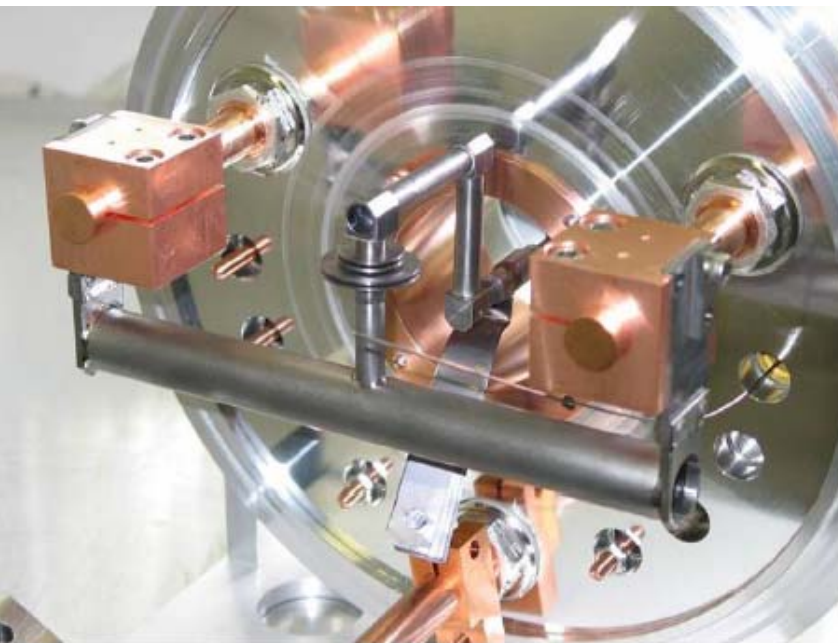

1<sup>st</sup> ISOLDE prototype of quartz glass transfer line

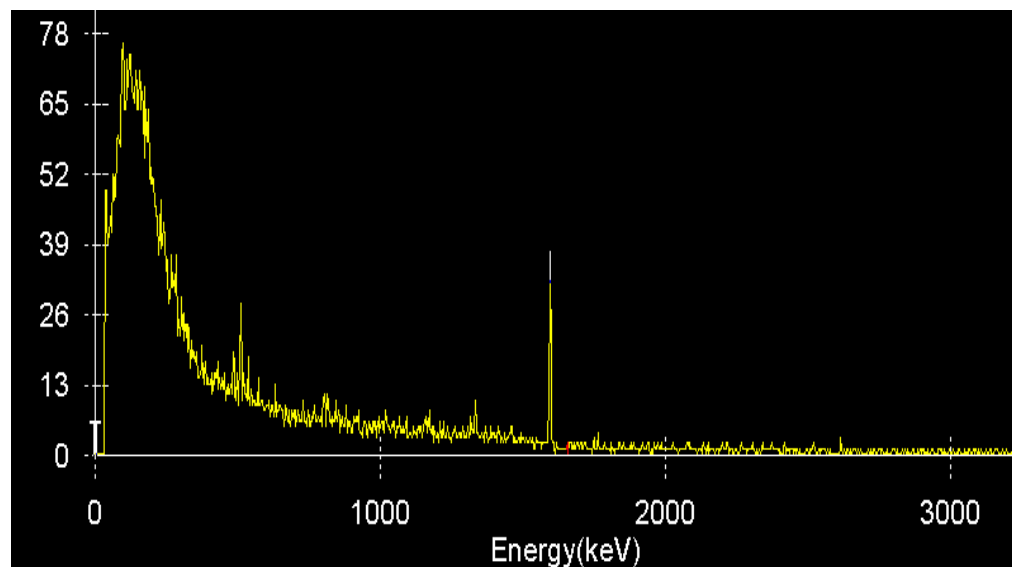

Acq. Start: 05-10-05 20:08:31      Elapsed      Preset  
Dead Time: 0.44%      Live (secs.): 333.49      0

**Laser-off gamma spectrum** collected for 12 seconds on mass 131, 3 $\mu$ A protons onto converter, quartz transfer line at 600 °C

All gamma lines are due to background on tape

► **Total suppression of surface ionized species (Cs, In)**

Properties of the quartz glass transfer line are currently being investigated further at CERN-ISOLDE

### New materials for different contaminations

#### **Ceramics:**

- refractory materials (high-temperature stable, low vapor pressure)
- variety of chemical compounds (different elements, polarities, electron densities)
- different molecular structures

Offline tests: Thermochromatographic setup @ TRIGA Mainz

Online tests: UNISOR (online test facility) @ Holifield Radioactive Ion Beam Facility (HRIBF), Oak Ridge

# Holifield Radioactive Ion Beam Facility

## HRIBF facility layout

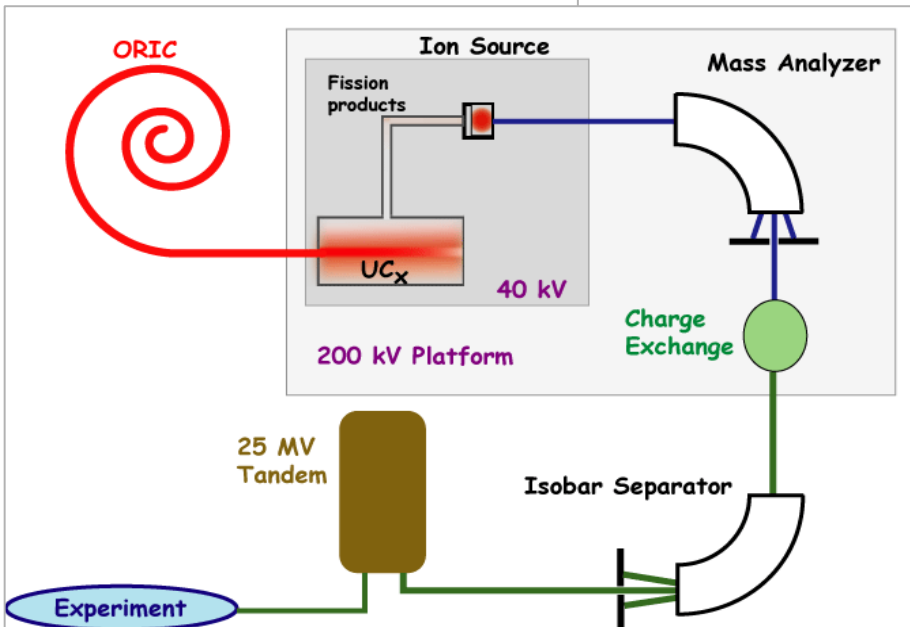
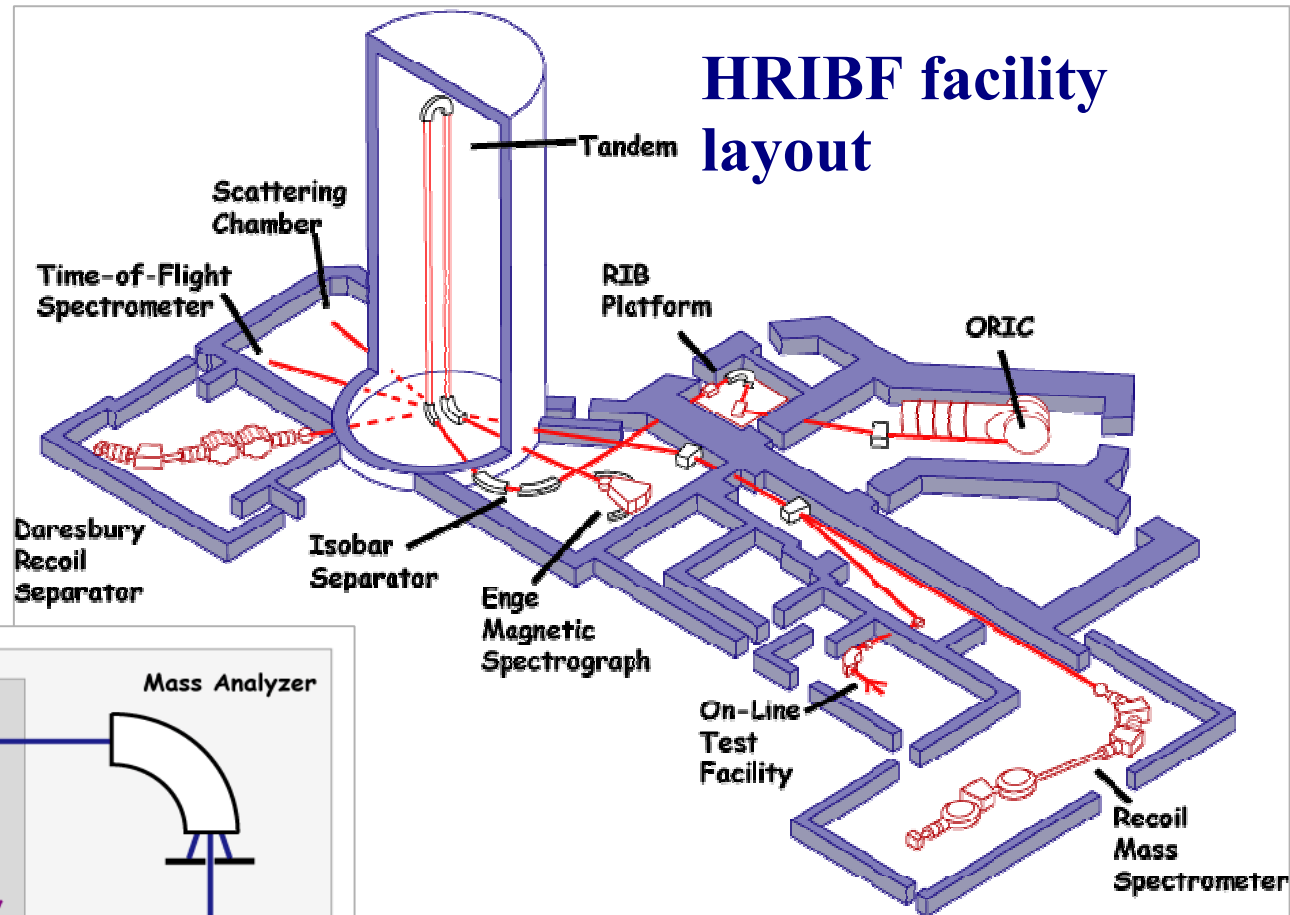

### ***On Line Test Facility:***

- ***Small-scale facility for online testing***
- ***Low proton beam ( $\leq 50$  nA)***
- ***Front-end (target and ion source) identical to RIB platform***
- ***Plasma ion source***
- ***Yields scalable to RIB platform***

### ***Experiments:***

- ***Yield measurements***
- ***Hold-up times***
- ***Charge exchange***
- ***Sample collection for offline experiments***

# Beam development at HRIBF: UNISOR / OLTF

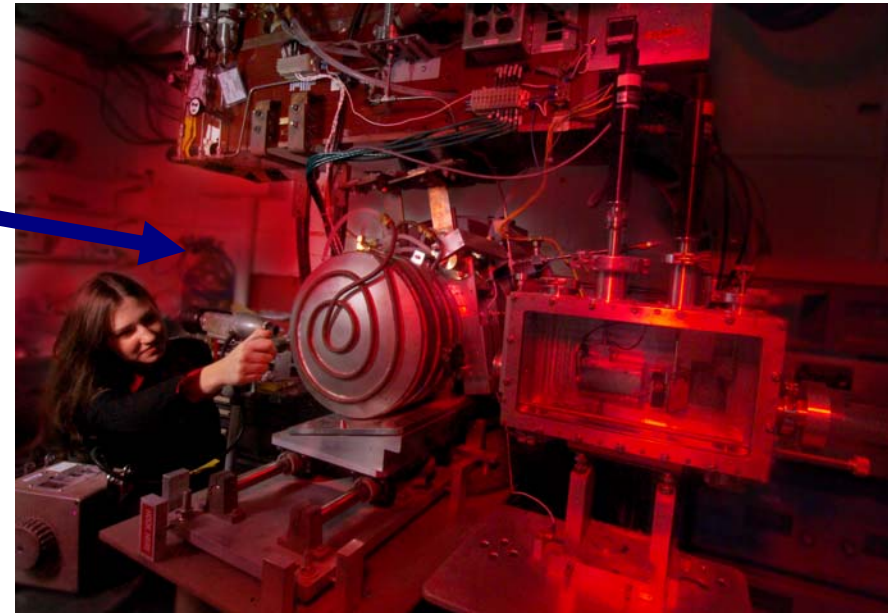
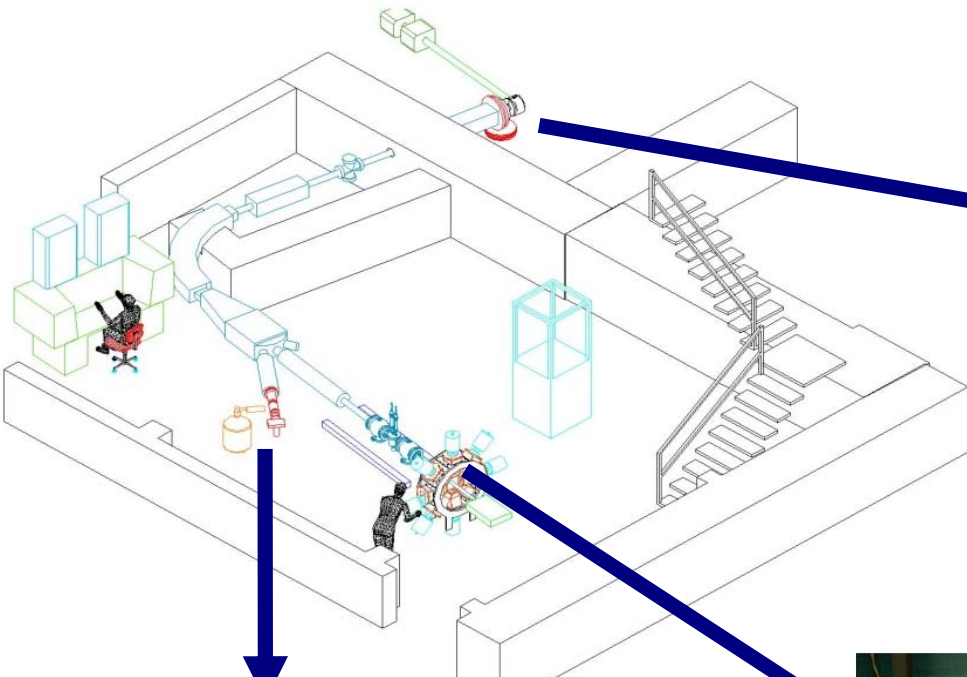

Target room

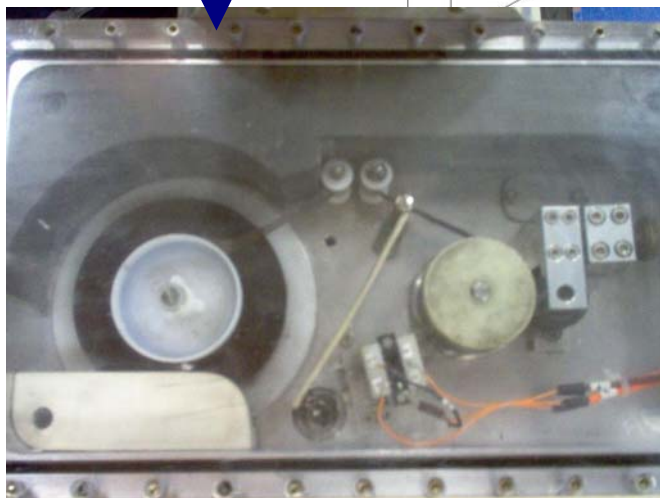

Tape station



Charge exchange cell

# Implementation of a temperature-variable transfer line

Plasma ion source with temperature-controlled transfer line

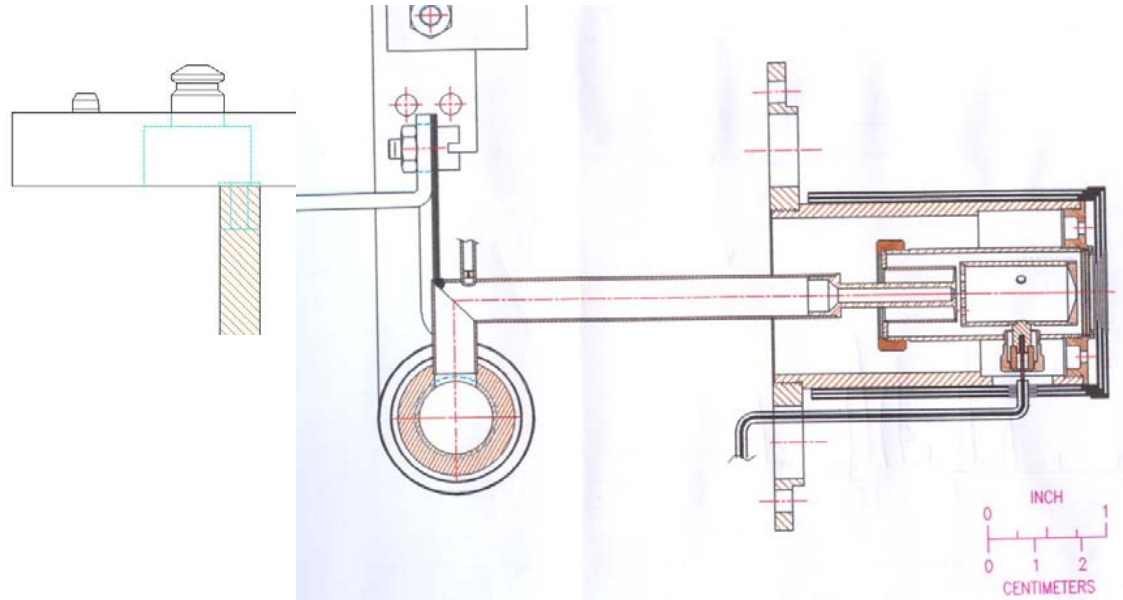
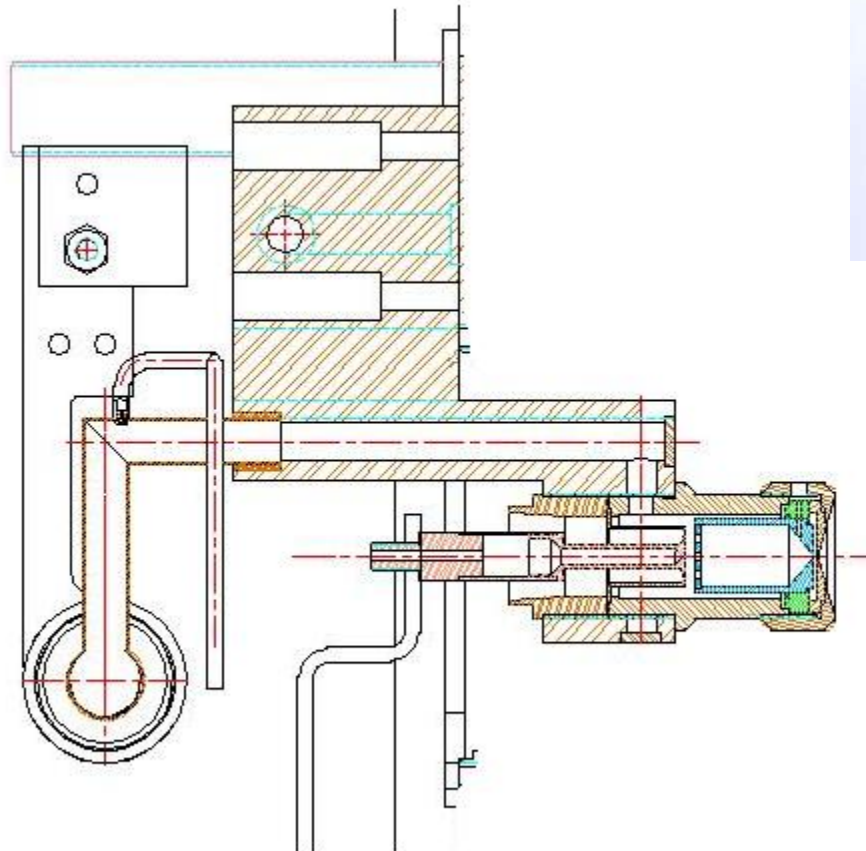

Standard plasma ion source (MK5)

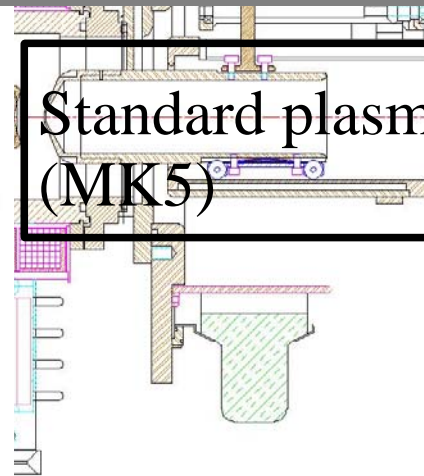

- **Mainz TC Experiments: O. Arndt<sup>1</sup>, I. Dillmann<sup>1</sup>, B. Eichler<sup>2</sup>, A. Hohn<sup>2</sup>, S. Hübener<sup>3</sup>, C. Jost<sup>1,7</sup>, U. Köster<sup>4,8</sup>, K.-L. Kratz<sup>1</sup>, H.J. Maier<sup>5</sup>, M. Mendel<sup>1</sup>, K. Peräjärvi<sup>4</sup>, B. Pfeiffer<sup>1</sup>, N. Trautmann<sup>1</sup>, C. Yilmaz<sup>1</sup>**
- **CERN TC Experiments: O. Arndt<sup>1</sup>, P. Everaerts<sup>6</sup>, H. Frånberg<sup>2</sup>, C. Jost<sup>1,7</sup>, U. Köster<sup>4,8</sup>, A. Kronenberg<sup>7</sup>**
- **Oak Ridge Experiments: H.K. Carter<sup>7</sup>, C. Jost<sup>1,7</sup>, A. Kronenberg<sup>7</sup>, C. Reed<sup>9</sup>, E. Spejewski<sup>7</sup>, D. Stracener<sup>9</sup>**
- **ISOLDE ion source development: E. Bouquerel, R. Catherall, J. Lettry, T. Stora**

**<sup>1</sup> Institut für Kernchemie Mainz; <sup>2</sup> PSI Villigen; <sup>3</sup> FZ Rossendorf; <sup>4</sup> CERN ISOLDE; <sup>5</sup> LMU München; <sup>6</sup> Ghent University; <sup>7</sup> Oak Ridge Associated Universities; <sup>8</sup> ILL Grenoble; <sup>9</sup> Oak Ridge National Laboratory**